

**DURO METALL**

A company of the Wieland Group

## Finished Parts Catalogue

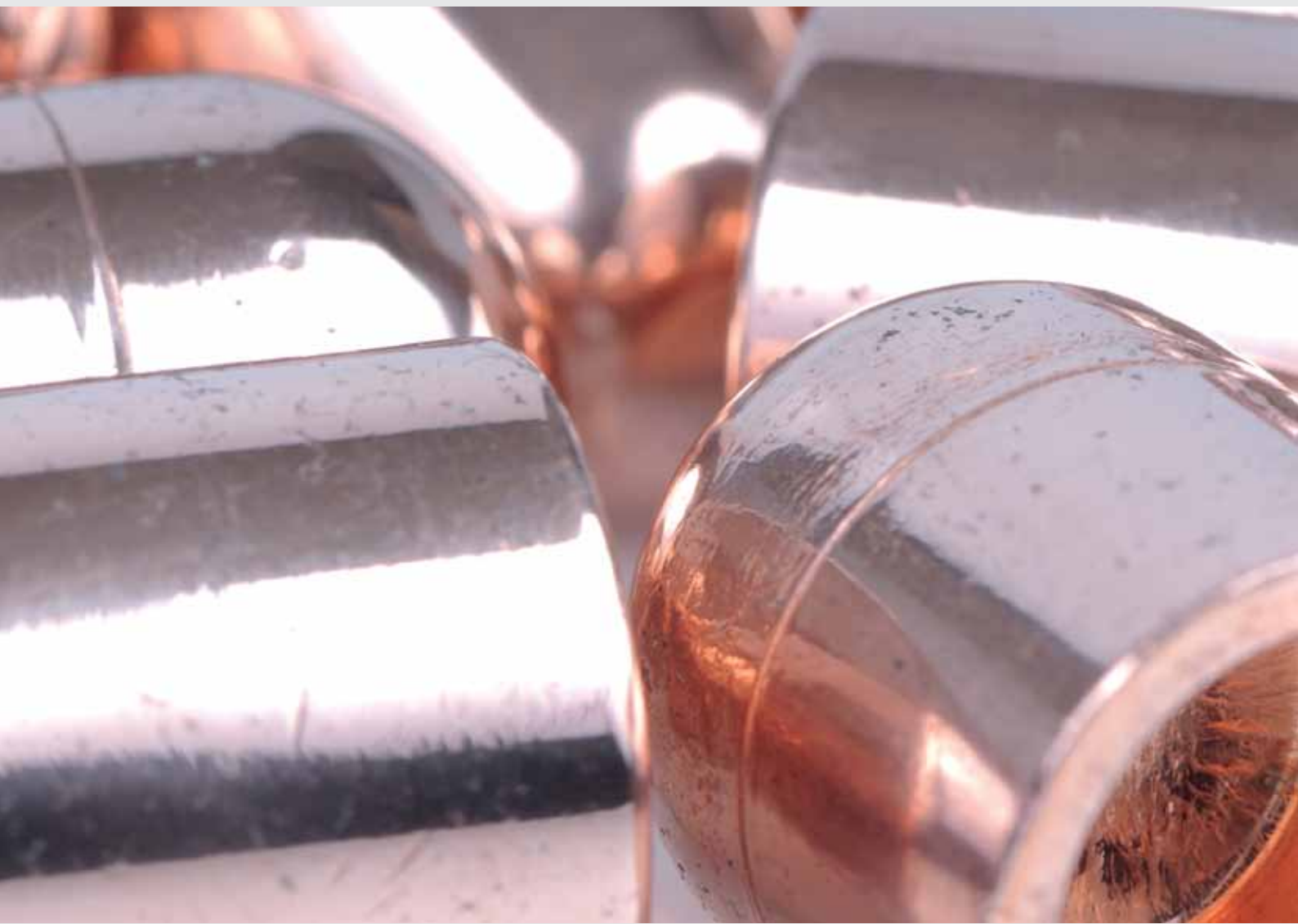

## 1. Electrode caps

Electrode caps acc. to DIN ISO 5821	3
Electrode caps with special length for milling cartridge	4
Special electrode caps (examples)	5
Electrodes acc. to DIN ISO 5830	6
Special shapes (examples)	6

## 2. Electrode holders

Electrode holders with threaded mounting	7
Special electrode holders (examples)	8
Bend electrode holders	8

## 3. Electrodes

Weld nuts electrodes	9
Electrodes with ball contact areas	10
Electrodes for the radiator welding	11
Straight spot welding electrodes	13
Standard electrodes with morse taper	15
Straight spot welding electrodes	16
Spot welding electrodes	18
Bend spot welding electrodes	19
Ball-type electrodes	21

## 4. Connecting cable

Air-cooled	22
Water-cooled	23

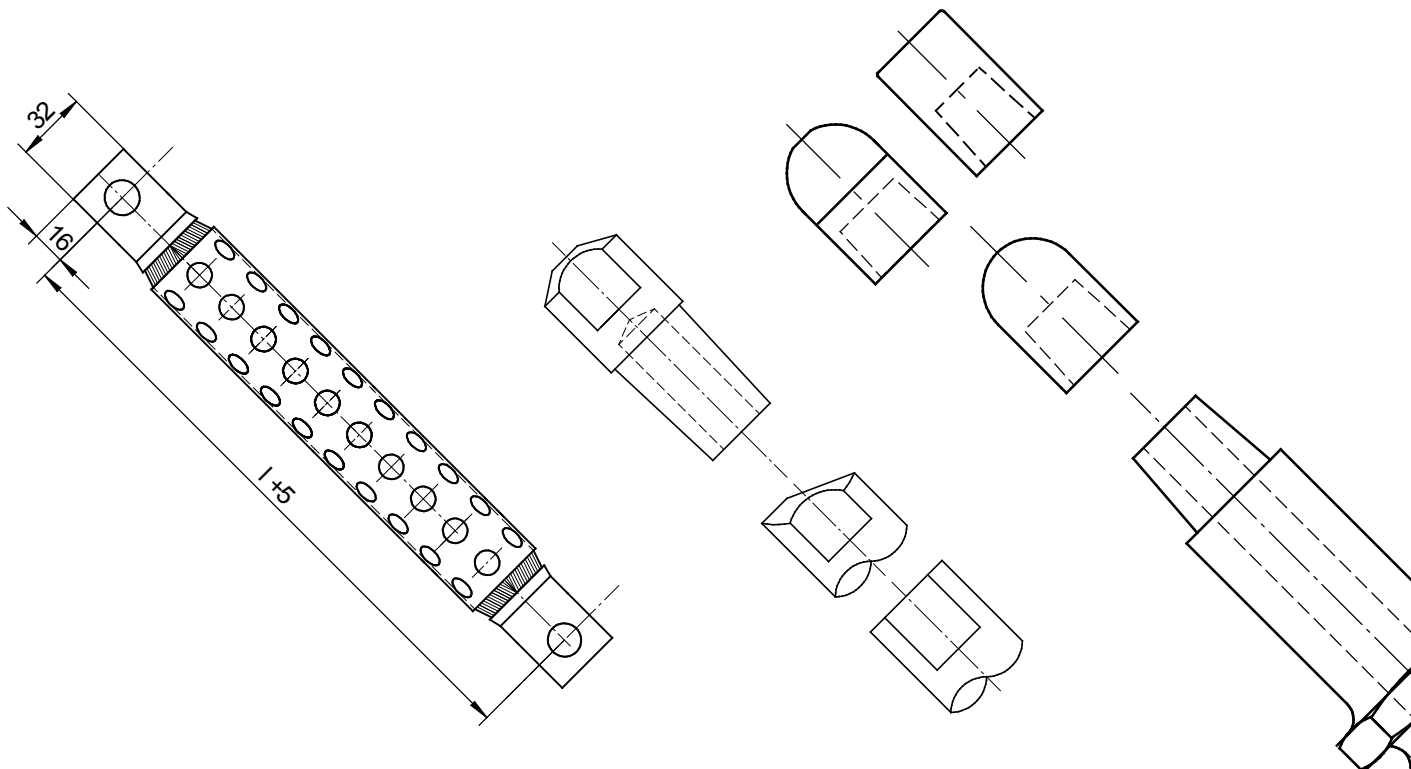

# Electrode caps acc. to DIN ISO 5821

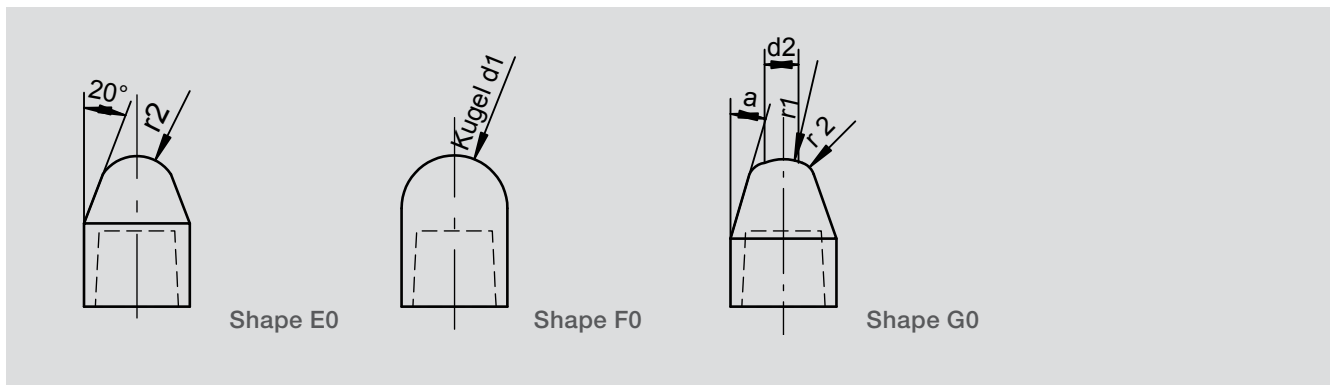
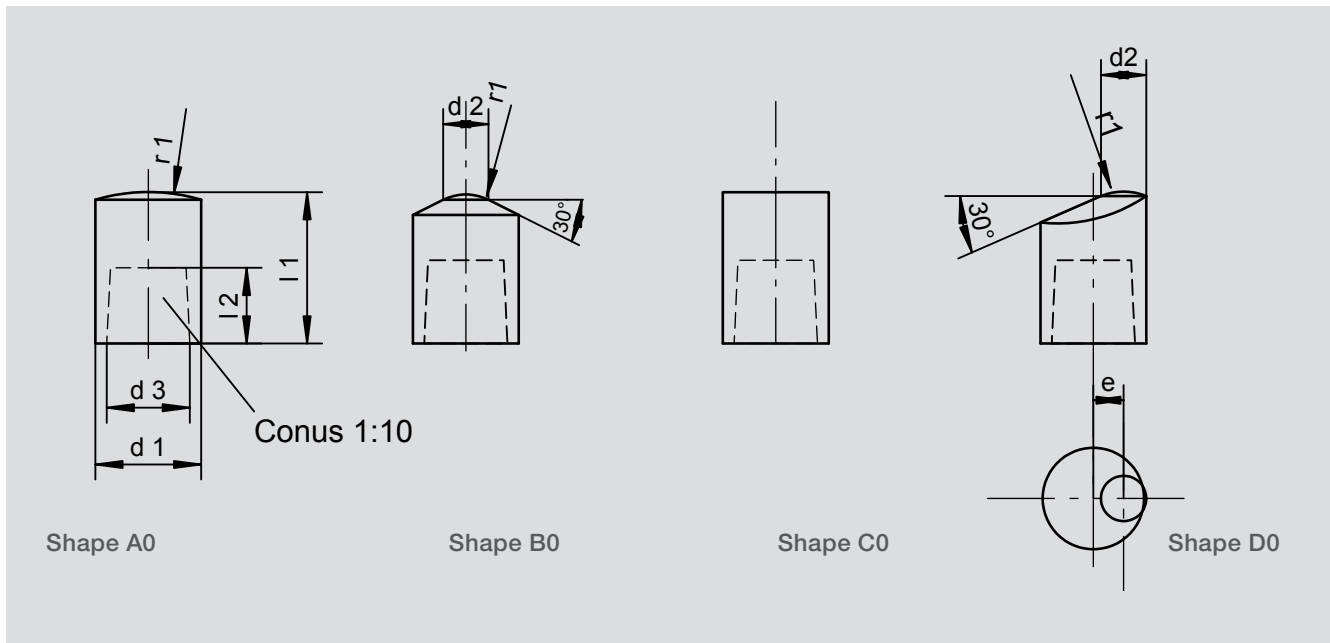

d1	d2	d3	l1	l2	e	r1	r2	a
13	5	10	18	8,5	3	32	5	
16	6	12	20	10,5	4	40	6	15°
20	8	15	22	12,0	5	50	8	22,5°

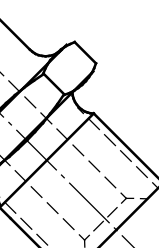

## Electrode caps with special length for the milling

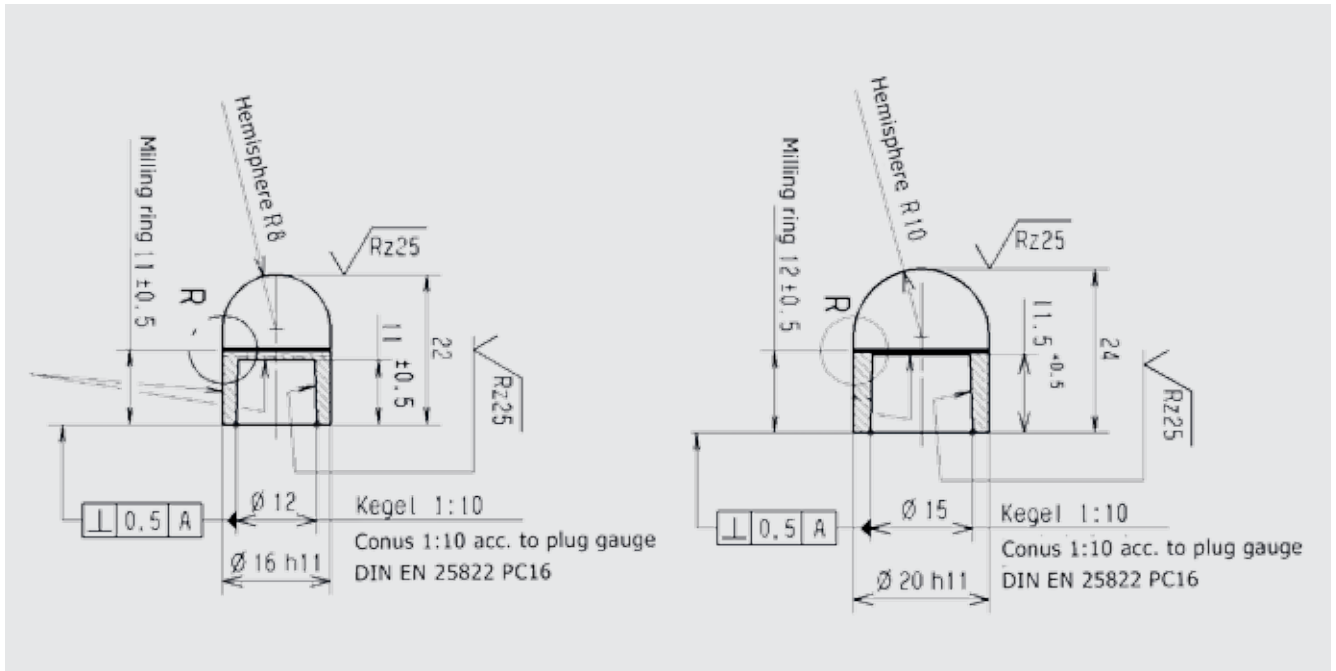

Type	d1	d2	d3	l1	l2	l3
F0 13	13	10		20	8,5	10
F0 16	16	12		22	11	11
F0 20	20	15		24	11,5	11,5
F1 16 Ø 5,5	16	12	5,5	22	11	11
F1 20 Ø 7,0	20	15	7,0	24	11	11,5

## Special electrode caps (examples)

Further dimensions on request

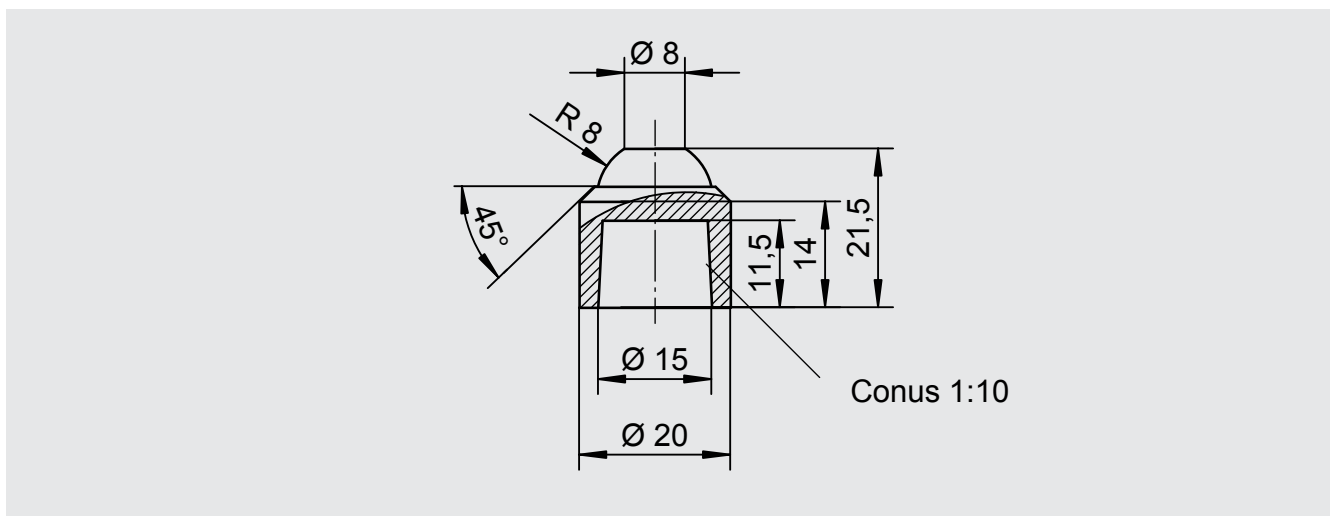
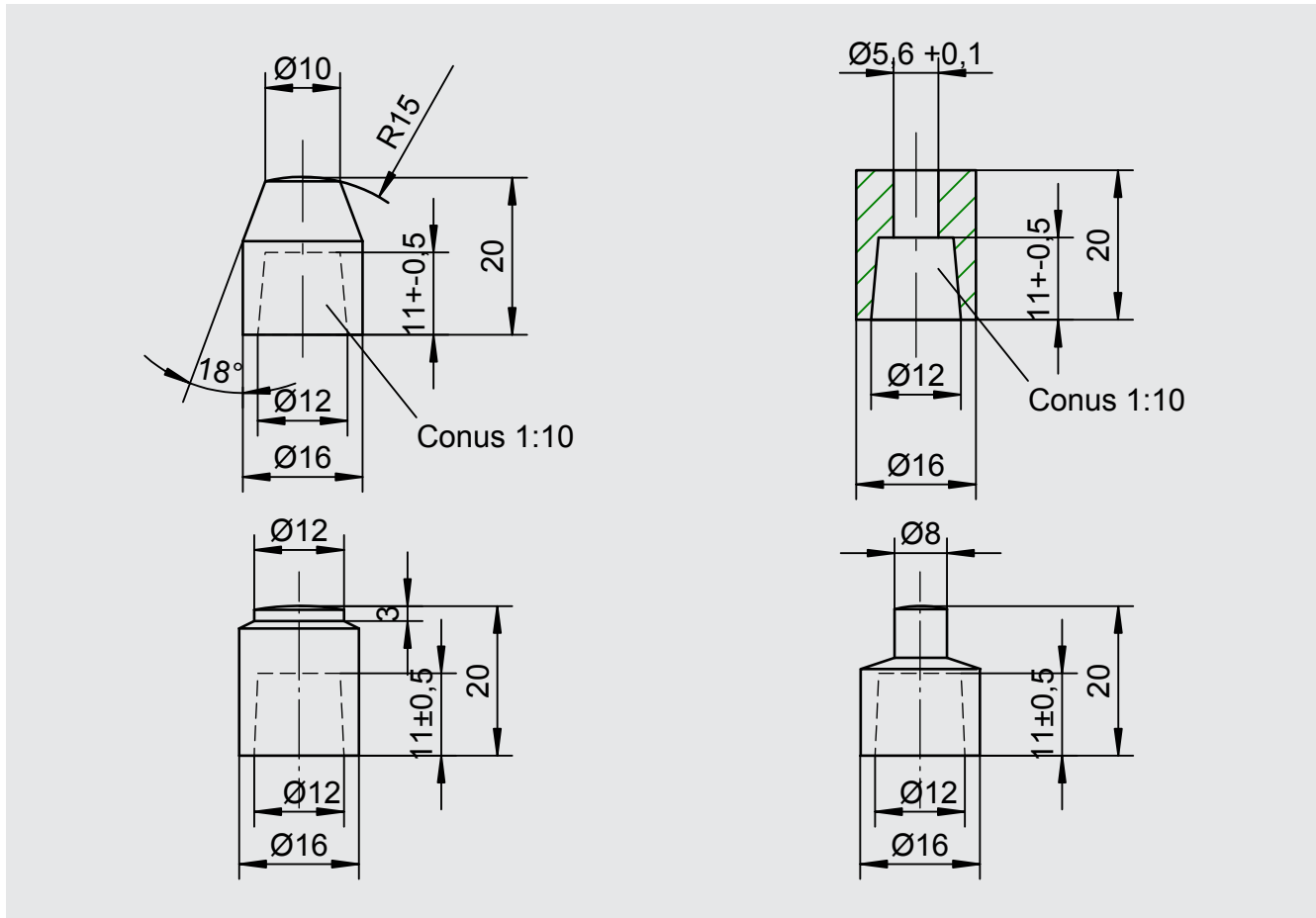

## Electrodes acc. to DIN ISO 5830

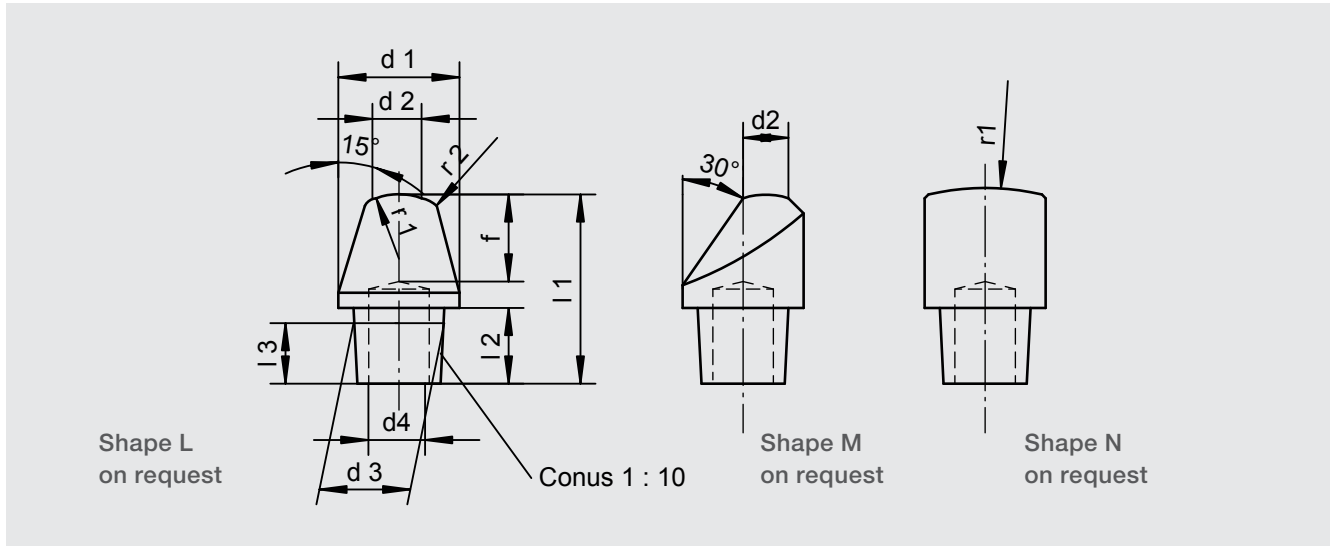

d1	d2	d3	d4	l1	l2	l3	f	r1	r2
16	6	11,8	8	25	10	6	10	40	6

## Special formats (examples)

Further delivery formats on request

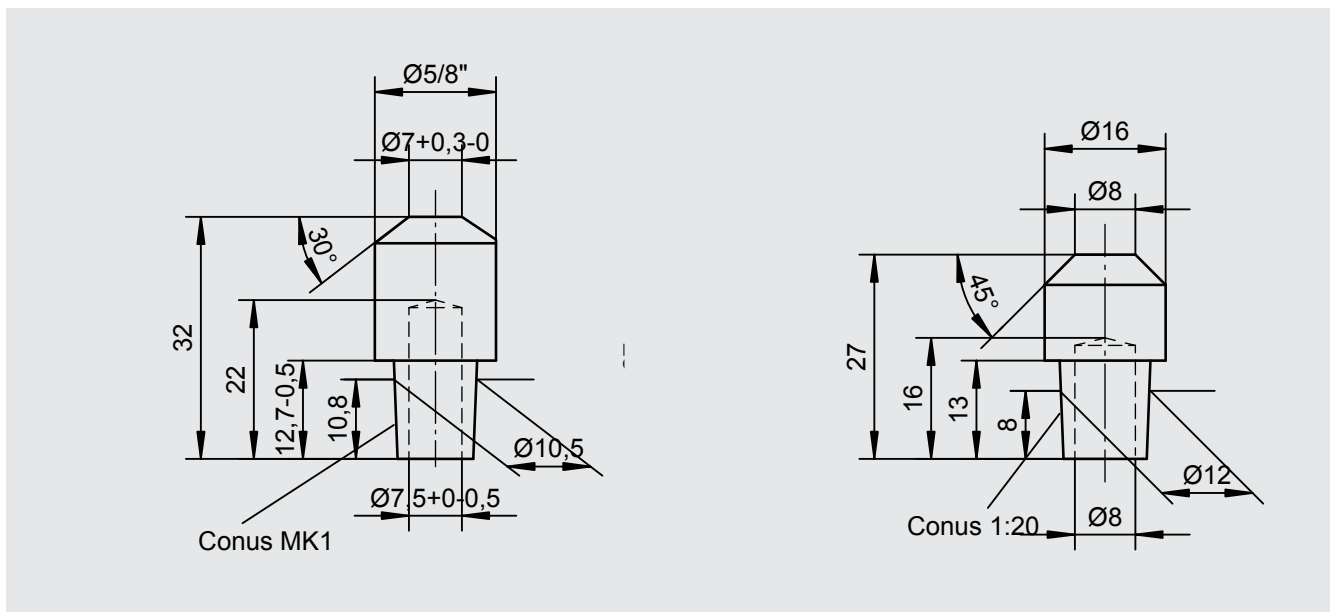

## Electrode holders

with threaded mounting and conus 1:10  
with diameter of mandrel 13 mm, 16 mm and 18 mm

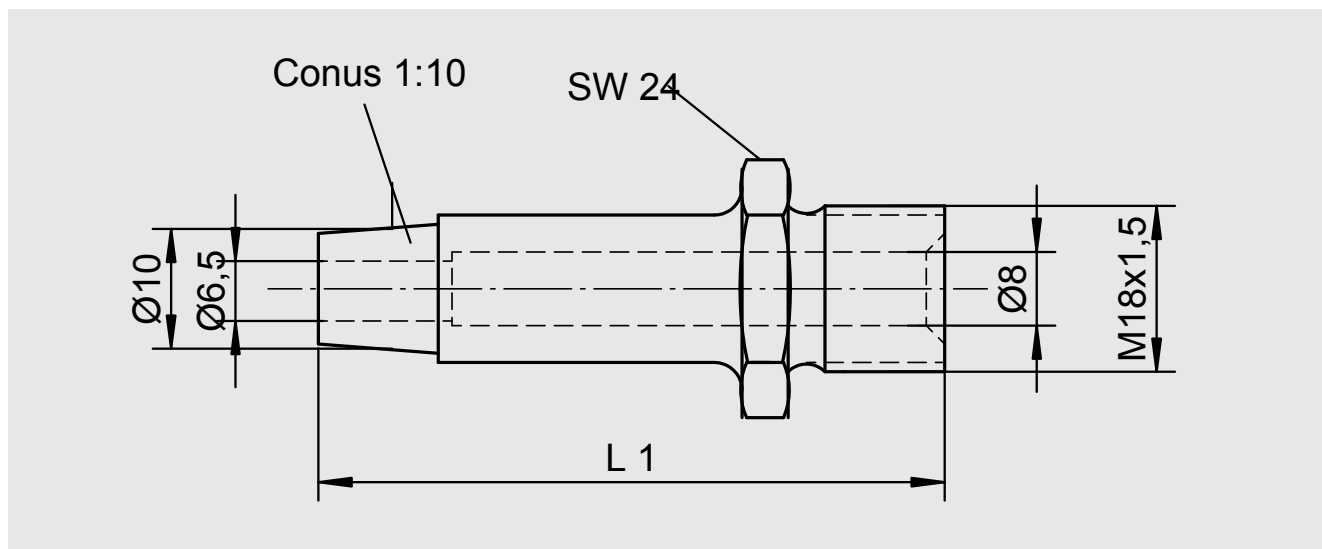

Material: Elmedur HA (CuCoNiBe)  
alternatively Elmedur NCS (CuNi<sub>2</sub>SiCr – Be free)  
alternatively Elmedur X (CuCrZr)

Normal lengths:

L 1	L 1
43,5	93,5
48,5	98,5
53,5	103,5
58,5	113,5
63,5	123,5
68,5	133,5
73,5	143,5
78,5	153,5
83,5	173,5
88,5	193,5

Further delivery formats on request

# Special electrode holder (examples)

Further delivery formats on request

With conus fixing and conus 1:10, shape A-G

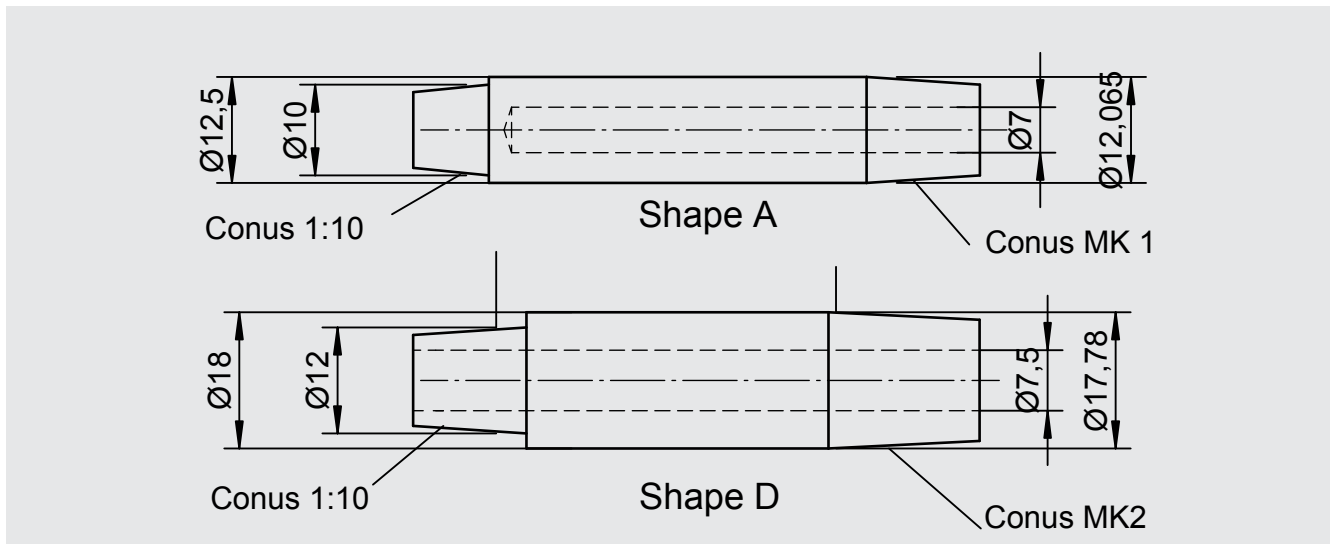

Material: Elmedur X, NCS or HA

# Bend electrode holder

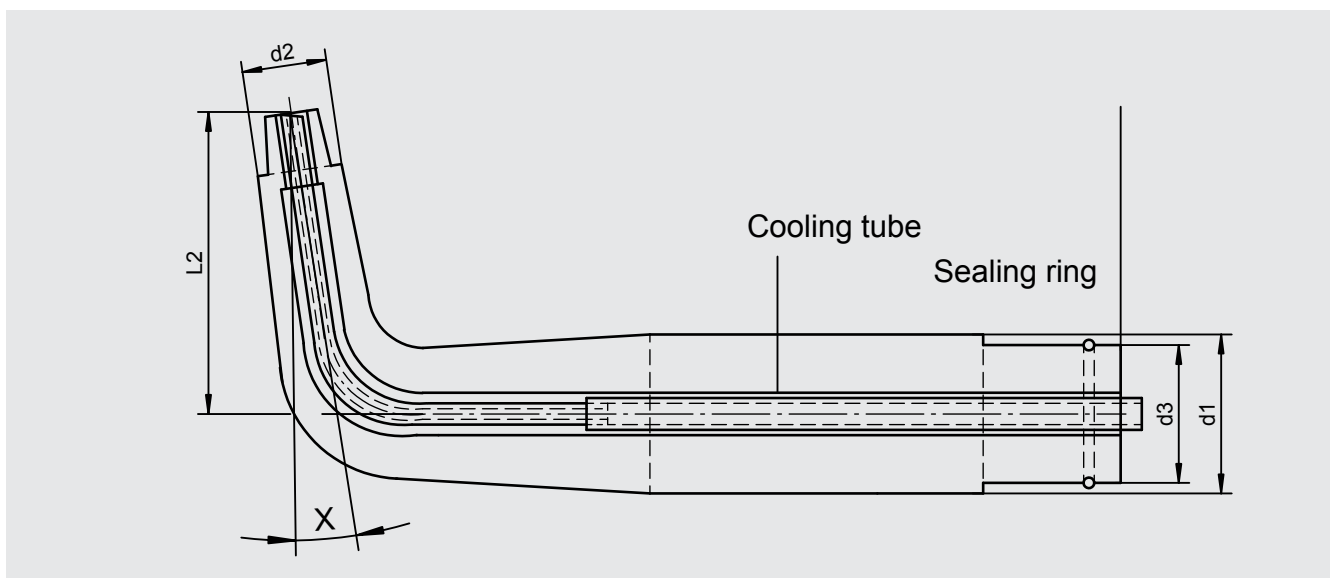

Material: Elmedur X or NCS available on request



## Weld nuts electrodes

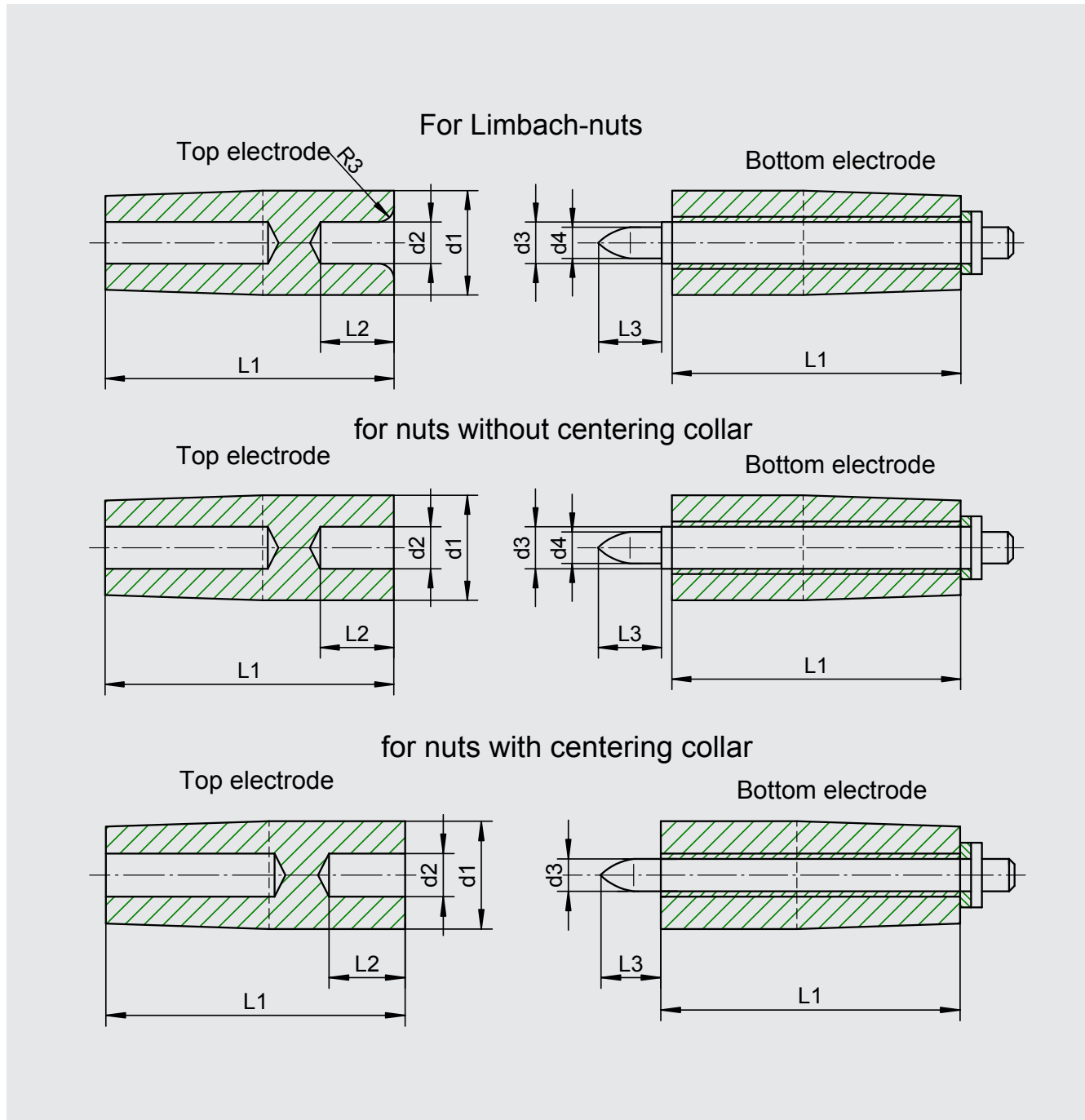

Weld nuts electrodes are nut threads M5-M12 and lengths  $L_1 = 40-70$  mm available  
Material: Elmedur NCS or HA

# Electrodes with ball contact areas

13 mm and 18 mm

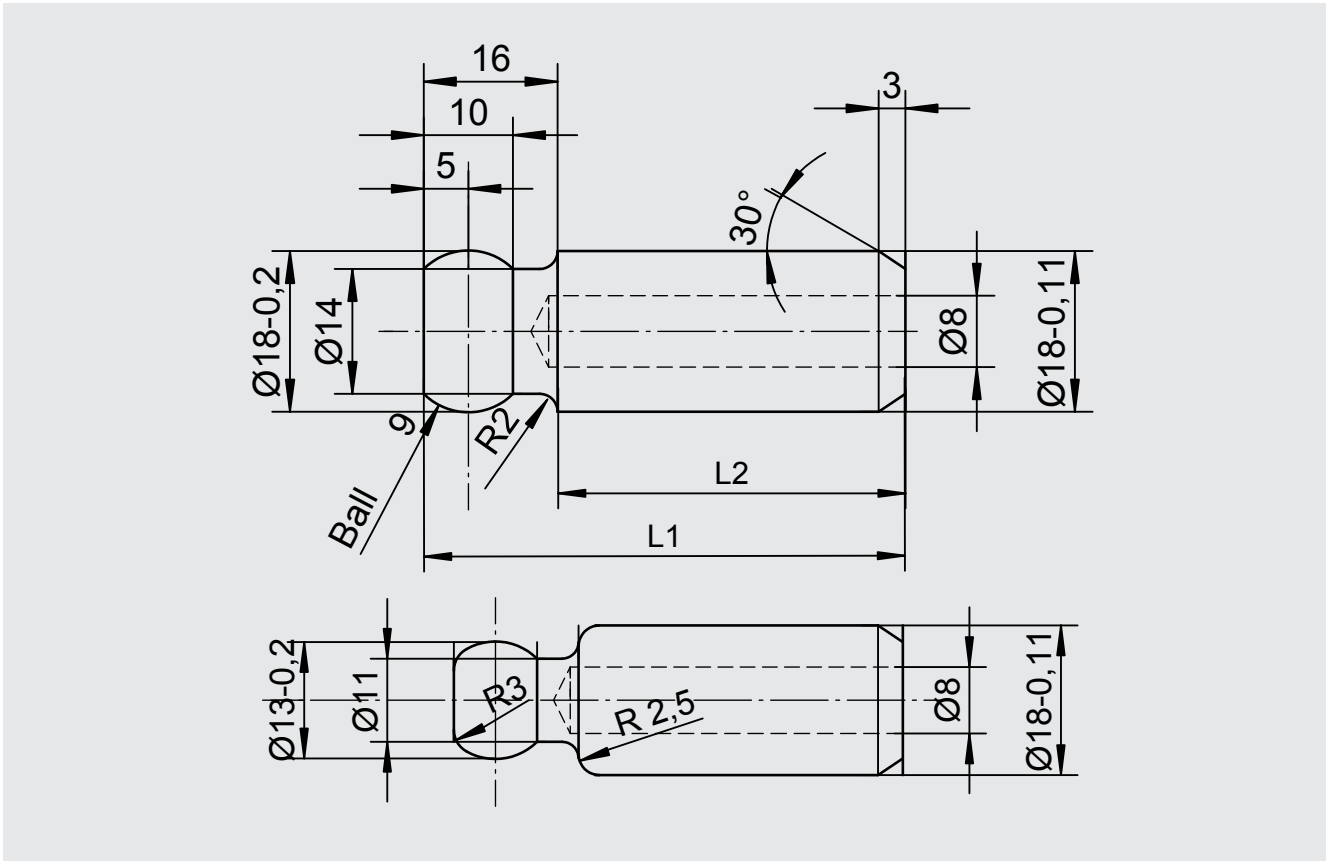

Ø 18 mm		Ø 13 mm	
L1	L2	L1	L2
45	30	45	30
50	35	50	35
55	40	55	40
60	45	60	45
65	50	65	50
70	55	70	55
75	60	75	60
80	65	80	65
90	75		

# Electrodes for the radiator welding

Further delivery formats on request

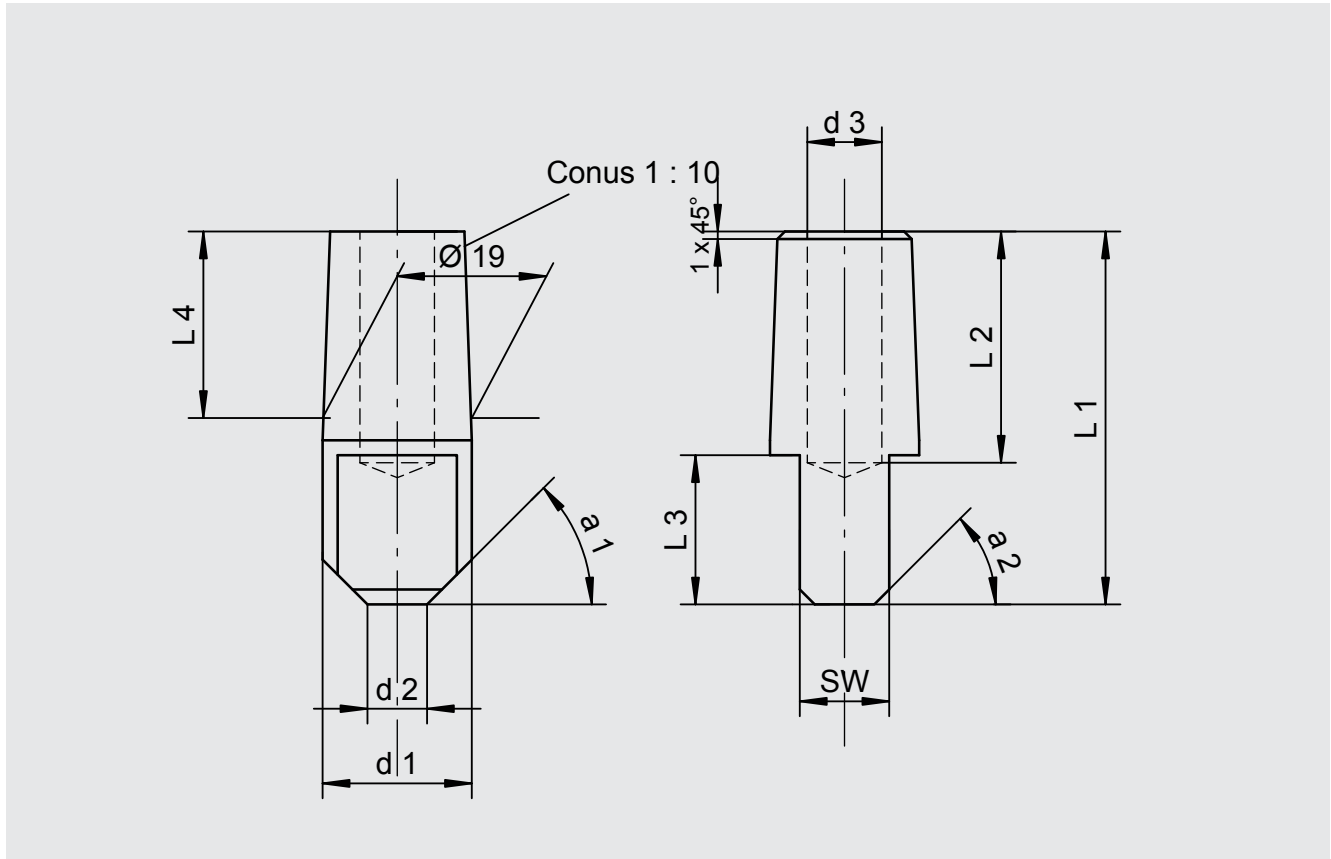

d1	d2	d3	L1	L2	L3	L4	SW	a1	a2
Ø 20	Ø 8	Ø 9	50	32	20	25	11	45	45
Ø 20	Ø 6	Ø 9	50	32	20	25	11	45	45
Ø 20	Ø 6	Ø 11	70	52	45	30	15		
Ø 20	Ø 6	Ø 9	45	27	22	20	15	30	30
Ø 20	Ø 8	Ø 9	45	27	22	20	15	30	30

## Electrodes for the radiator welding

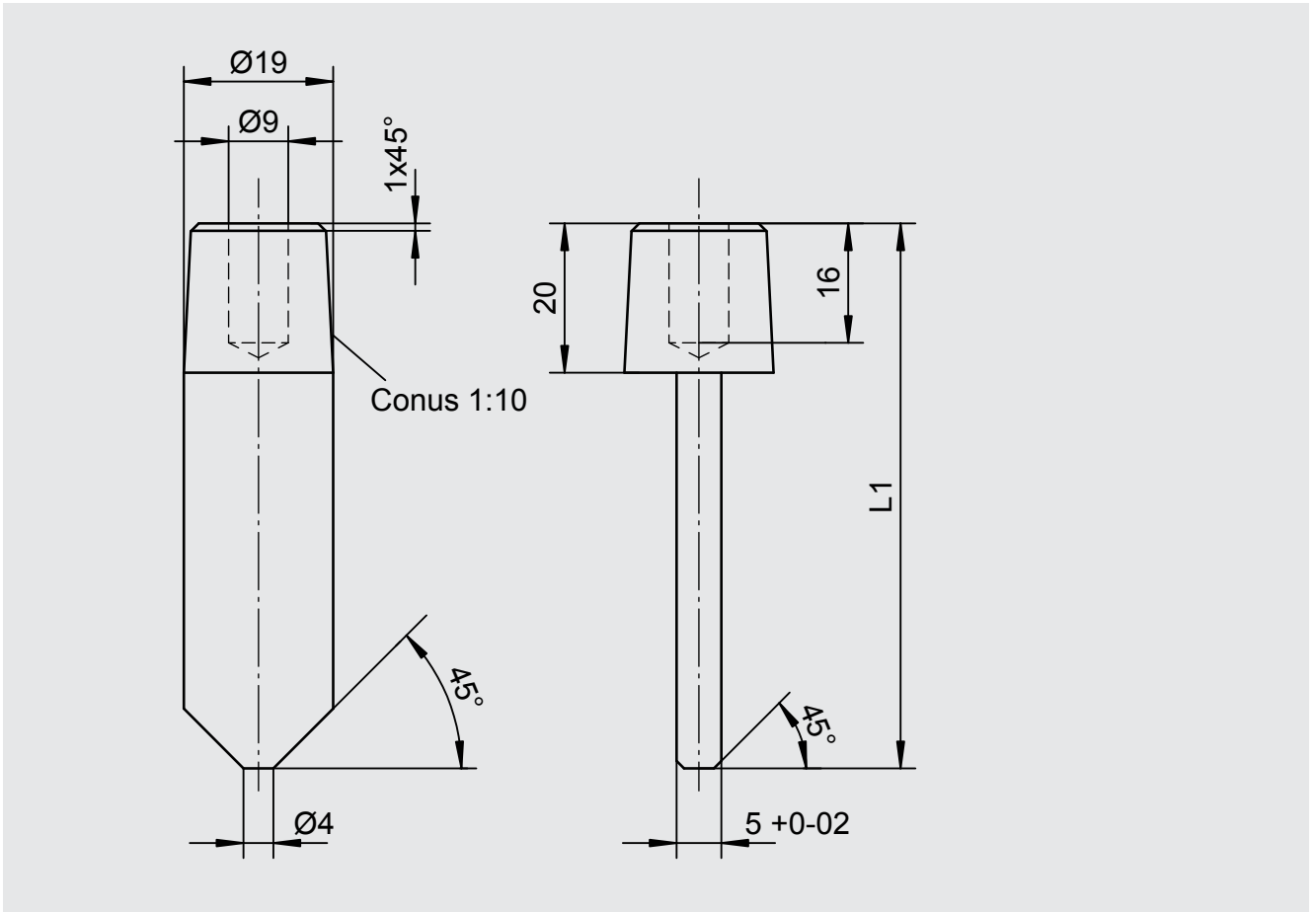

Any length can be produced to customers' request.

Material: Elmedur HA

# Straight spot welding electrodes

for general applications

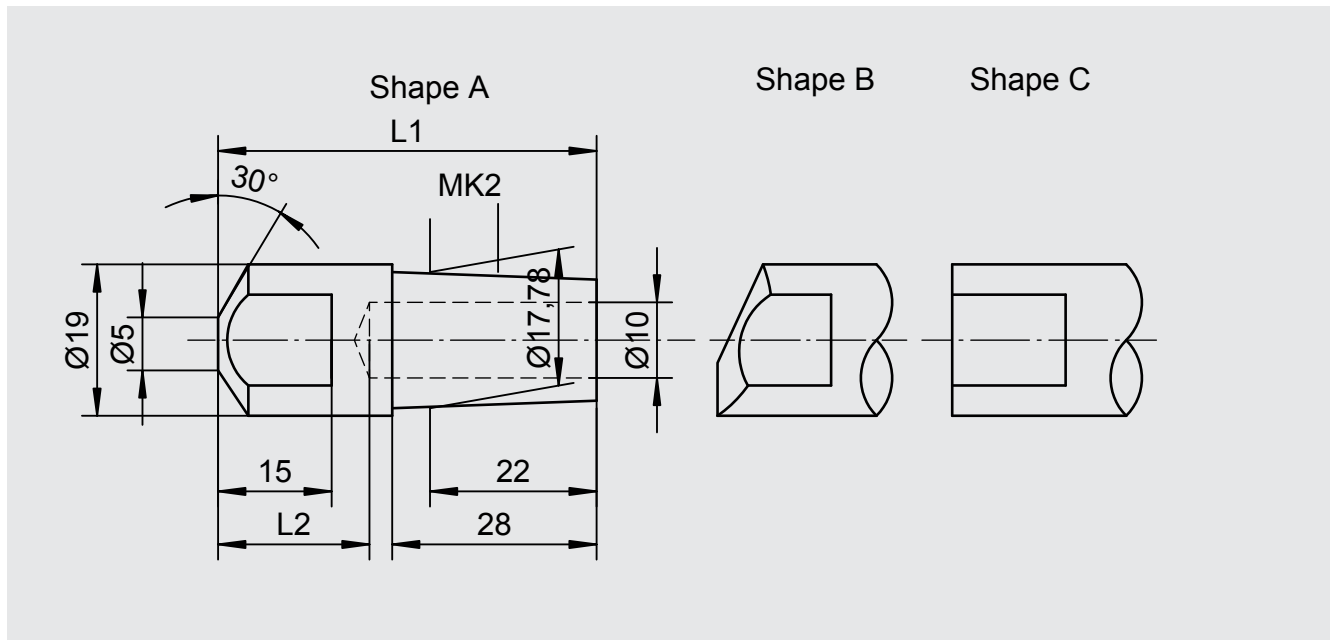

Material: Elmedur X, (CuCrZr)

Shape	L1	L2	Type
A	50	18	50000
A	60	20	50111
A	75	25	50222
B	50	18	51000
B	60	20	51111
B	75	25	51222
C	50	18	52000
C	60	20	52111
C	75	25	52222

# Straight spot welding electrodes

for general applications

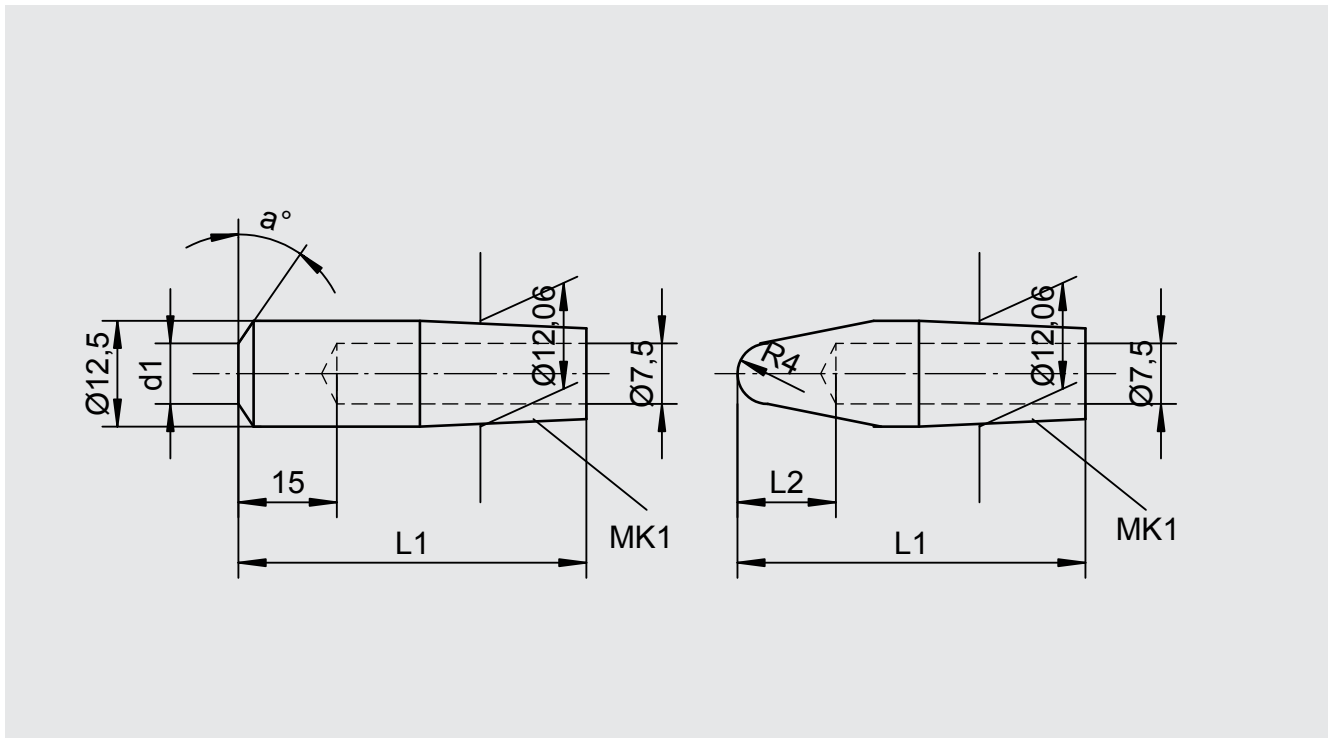

Material: Elmedur X (CuCrZr)

d1	L1	a	Type
6	40	30°	6030
6	45	30°	6031
6	50	30°	7032
6	60	30°	8000
5	45	60°	10000
5	60	60°	11000
5	75	60°	12000
6	40	75°	13000

L1	L2	Type
45	15	23000
60	15	24000
75	25	25000

# Standard electrodes

with Morse taper

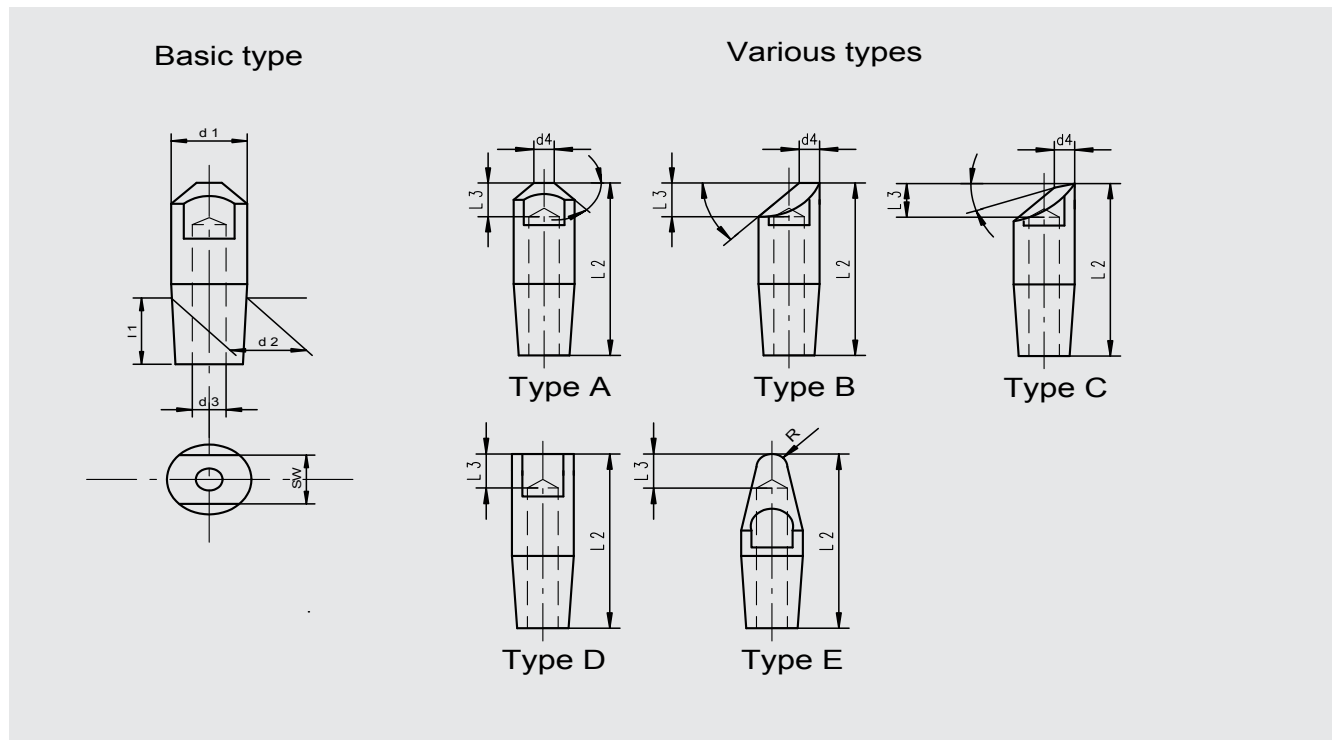

Fit	L1	d1	d2	d3	SW
MK1	14	12,5	12,065	8,0	11
MK2	22	18,0	17,780	9,5	17
MK3	30	30,0	23,825	12,5	22

Type	Conus	L2	L3	d4	Angle
A	MK1	34	14	5	45°
A	MK1	54	14	5	45°
A	MK1	74	14	5	45°
A	MK2	52	18	6,5	30°
A	MK2	72	18	6,5	30°
B	MK1	34	14	5	45°
B	MK1	54	14	5	45°
B	MK1	74	14	5	45°
B	MK2	52	18	6,5	30°
B	MK2	72	18	6,5	30°
C	MK1	34	14	4	15°
C	MK2	47	18	5	15°

Type	Conus	L2	L3	Radius
D	MK1	34	14	
D	MK1	54	14	
D	MK1	74	14	
D	MK2	52	18	
D	MK2	72	18	
E	MK1	34	14	3,5
E	MK1	54	14	3,5
E	MK1	74	14	3,5

# Straight spot welding electrodes

for general applications

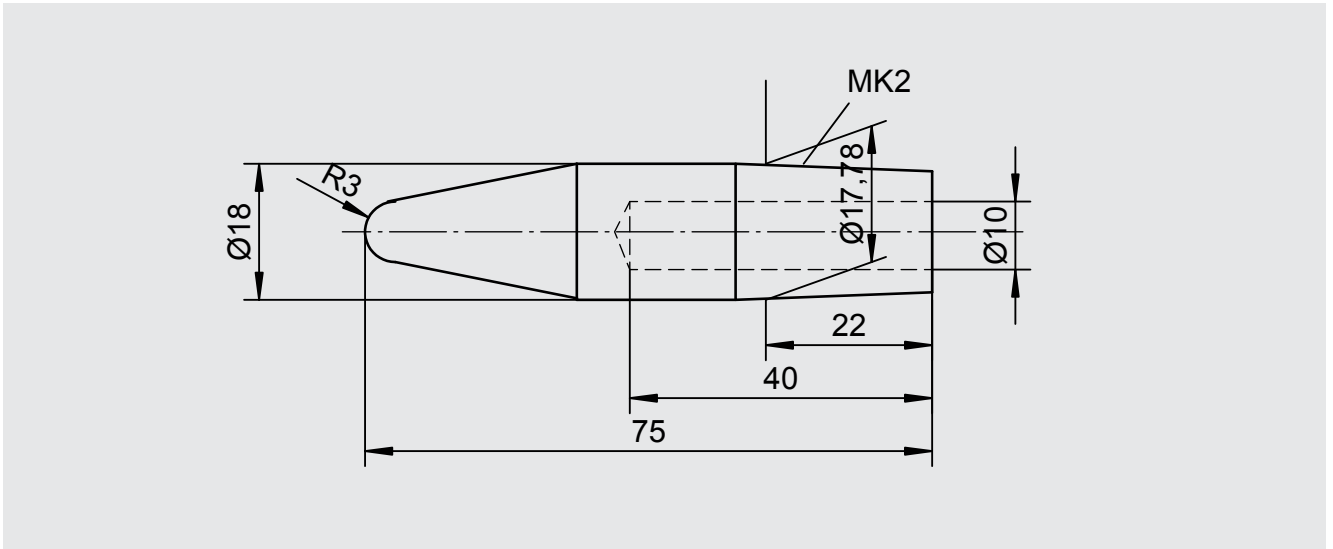

Type 45000  
Material: Elmedur X (CuCrZr)

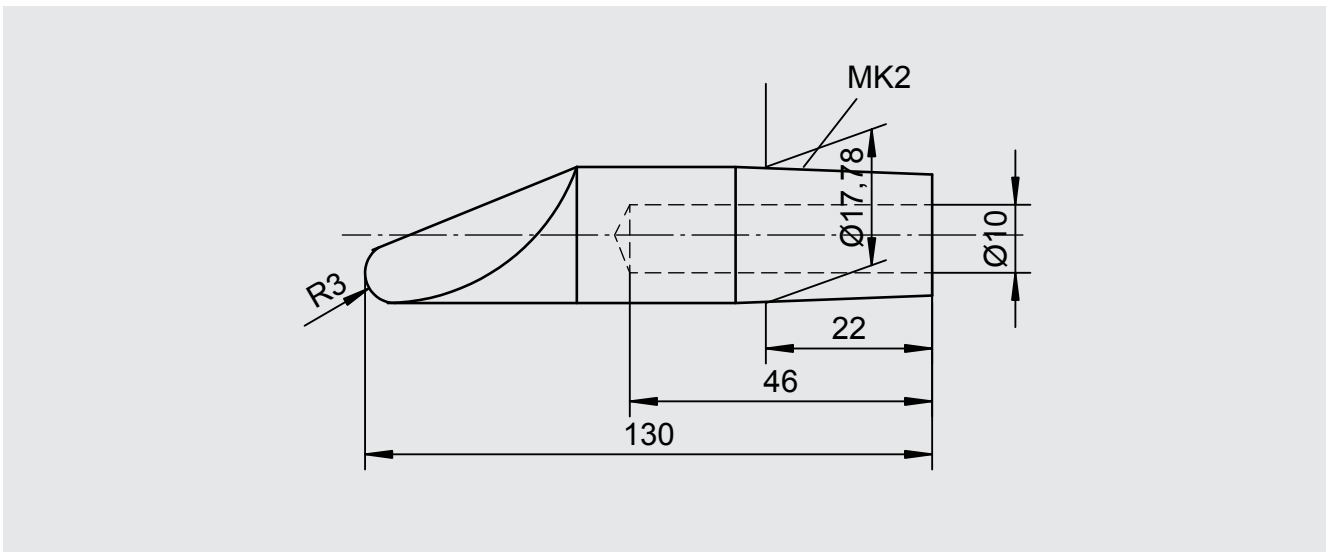

Type 47000  
Material: Elmedur X (CuCrZr)



# Straight spot welding electrodes

for general applications

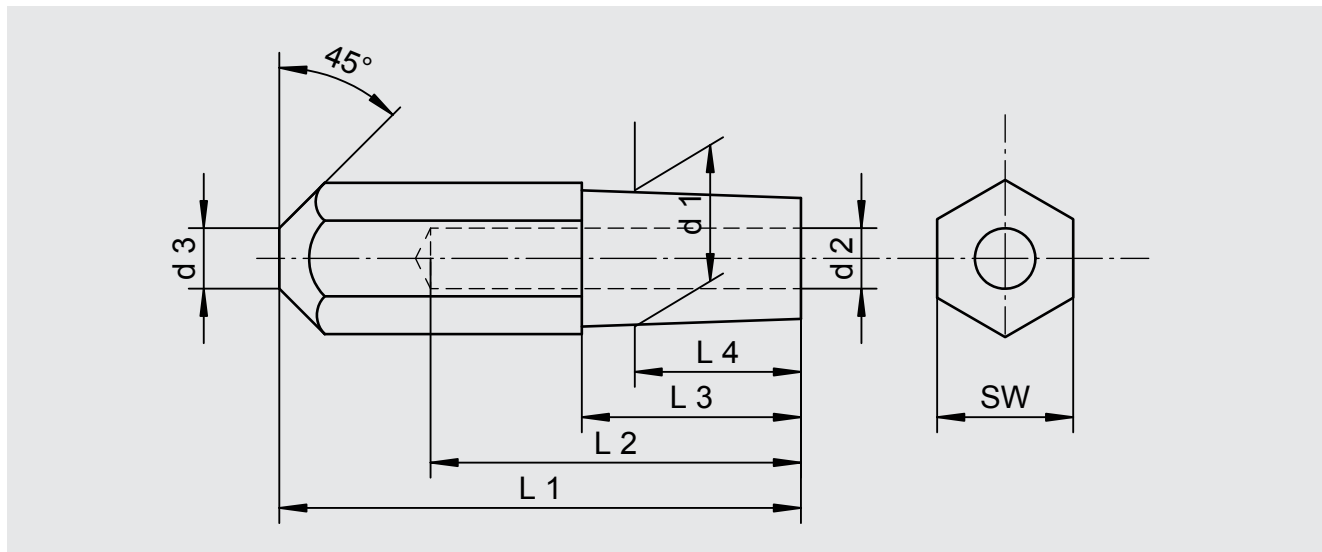

Material: elmedur X (CuCrZr)

L1	L2	L3	L4	d1	d2	d3	SW	Conus	Type
35	20	15	11	12,00	6,5	4	12	1:10	60000
45	25	15	12	12,06	8	4	12	MK1	62388
75	55	38	22	17,78	10	5	19	MK2	65000
100	75	38	22	17,78	10	5	19	MK2	66000

# Spot welding electrodes

for general applications

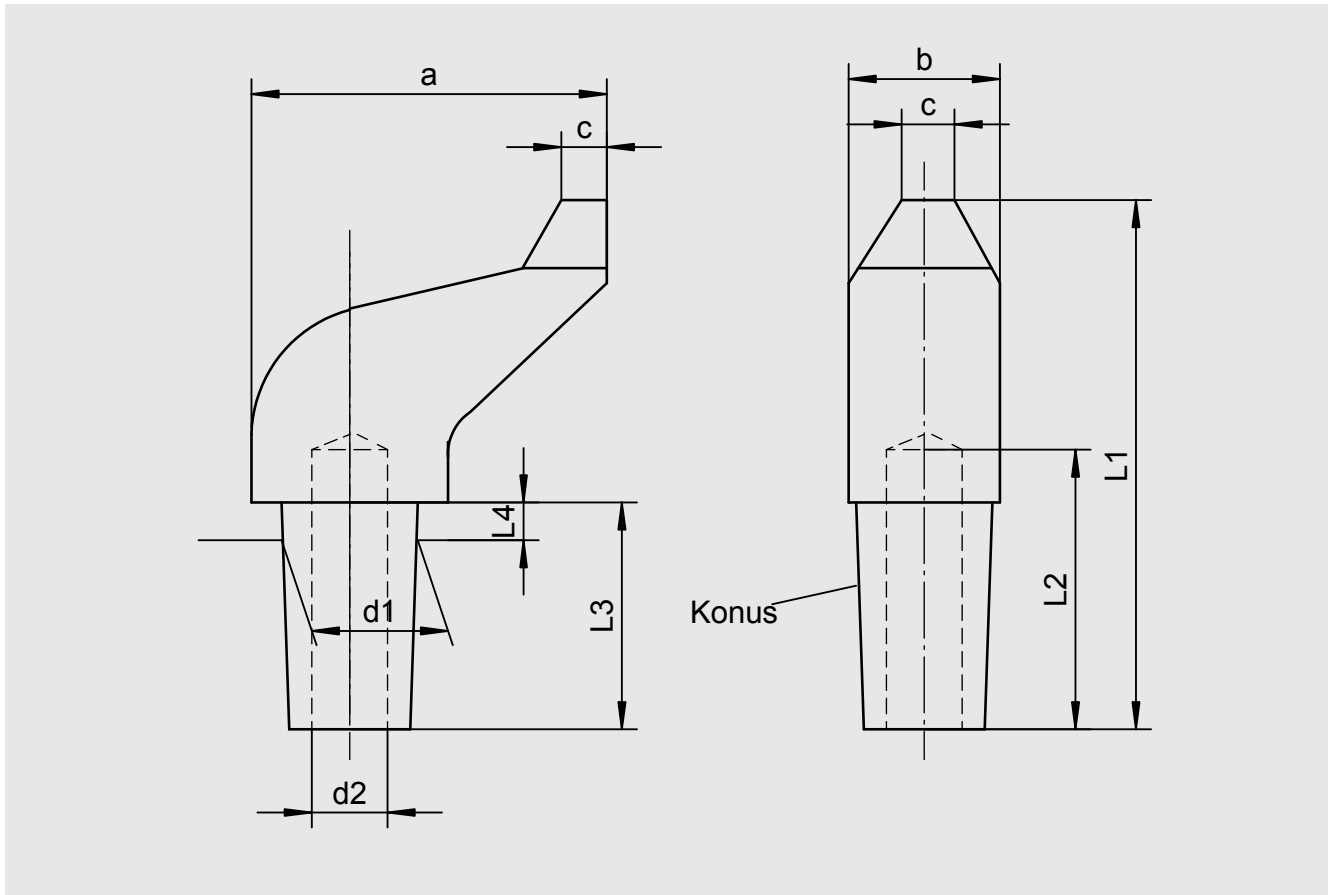

Material: Elmedur X (CuCrZr)

L1	L2	L3	L4	d1	d2	a	b	c	Conus	Type
35	20	15	3	10,5	6,5	22	12	5	1:10	82405
45	25	15	3	12,06	8	30	15	5	MK1	82406
75	45	28	3	17,78	10	35	20	7	MK2	82407

# Bend spot welding electrodes

for general applications

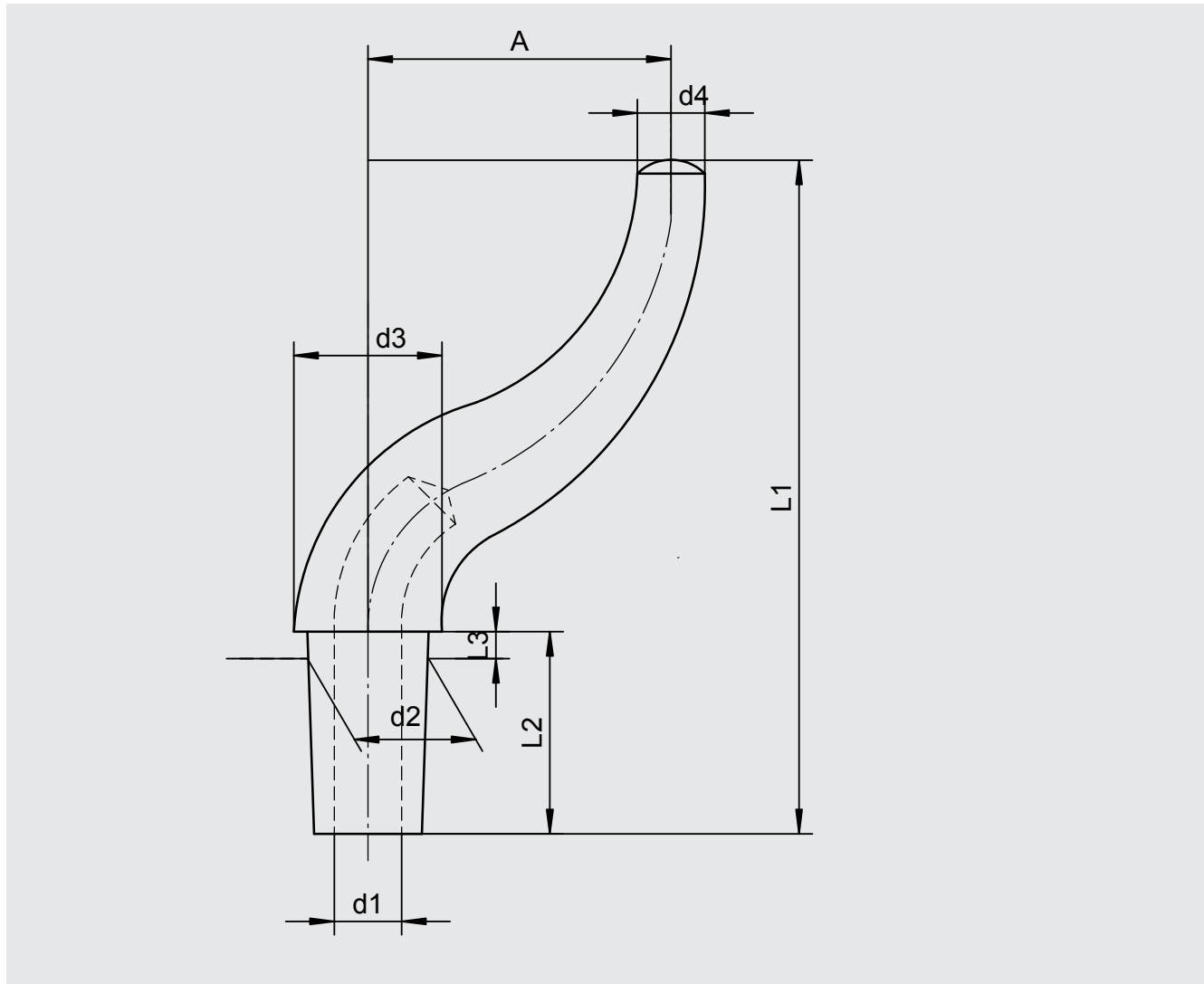

Material: Elmedur X (CuCrZr)

L1	L2	L3	d1	d2	d4	A	Conus	Type
91	28	6	17,78	20	8	45	MK2	83000
110	28	6	17,78	25	10	45	MK2	83111
110	28	6	23,82	25	10	45	MK3	83222
110	28	6	18	25	10	45	1:10	83333
140	38	6	17,78	20	12	60	MK2	83249

# Bend spot welding electrodes

for general applications

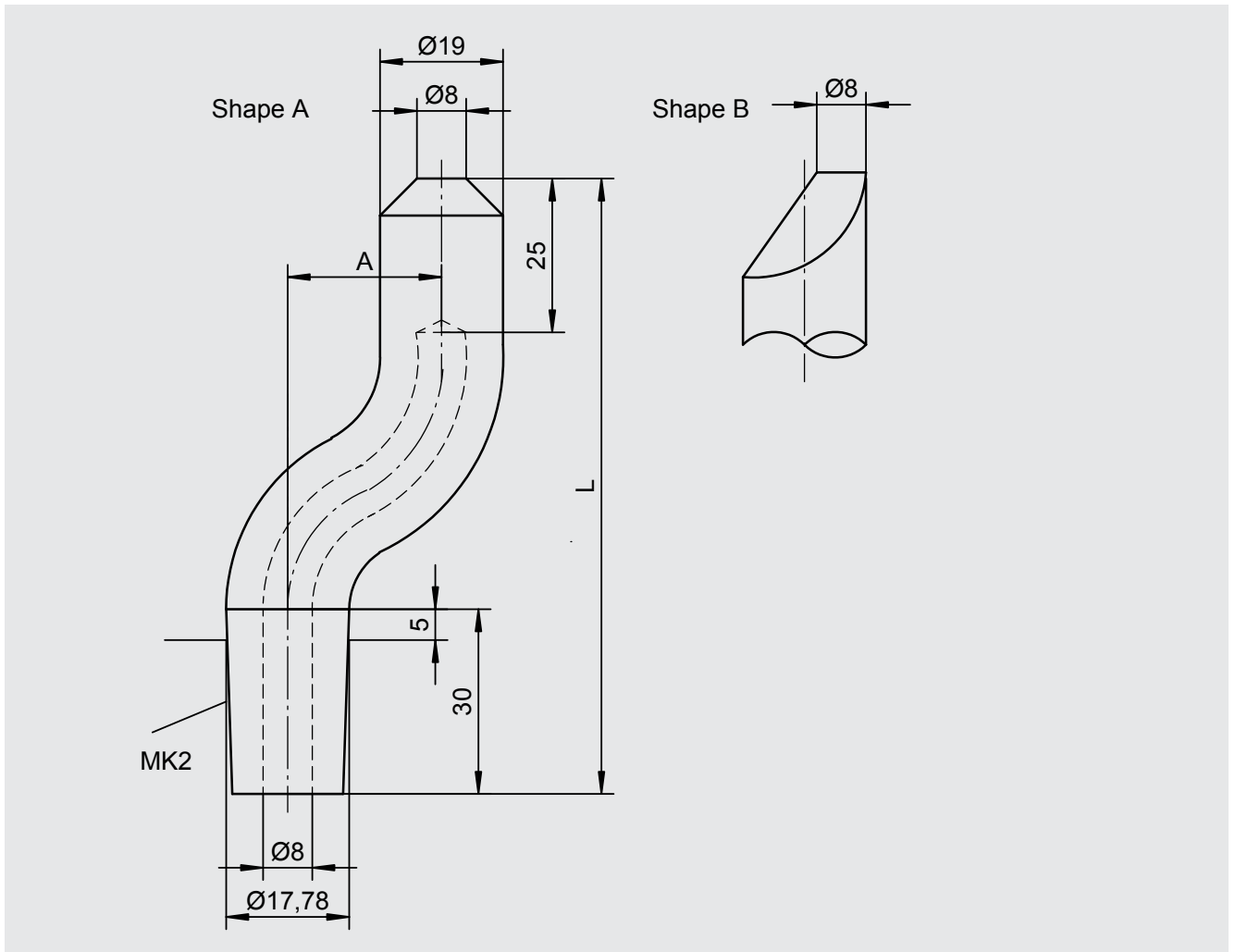

Material: Elmedur X (CuCrZr)

Shape	L	A	Type
A	84	15	84000
A	94	25	84111
B	84	15	85000
B	94	25	85111

## Ball-type electrodes

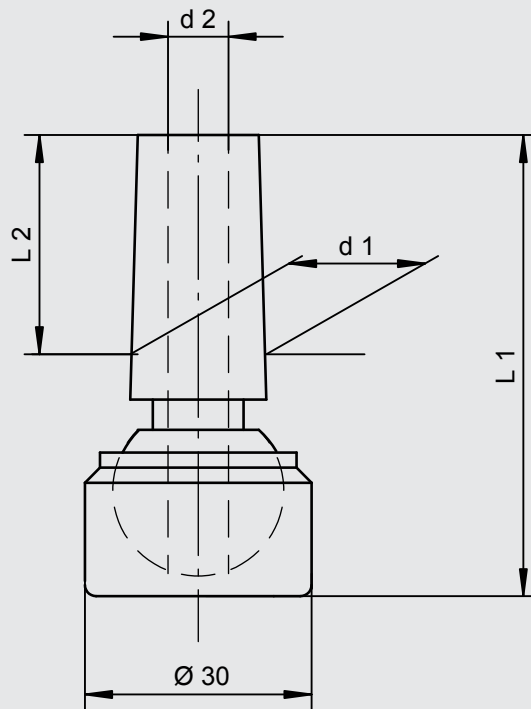

Material: Elmedur X (CuCrZr)

Conus	L1	L2	d1	Angle	Type
MK1	45	15	12,06	7	86000
MK2	56	22	17,78	10	86111
1:10	43	12	9,10	6	86222
1:10	45	16	12,00	7	86333
1:10	52	22	18,00	12	86444

# Connecting cable

air-cooled

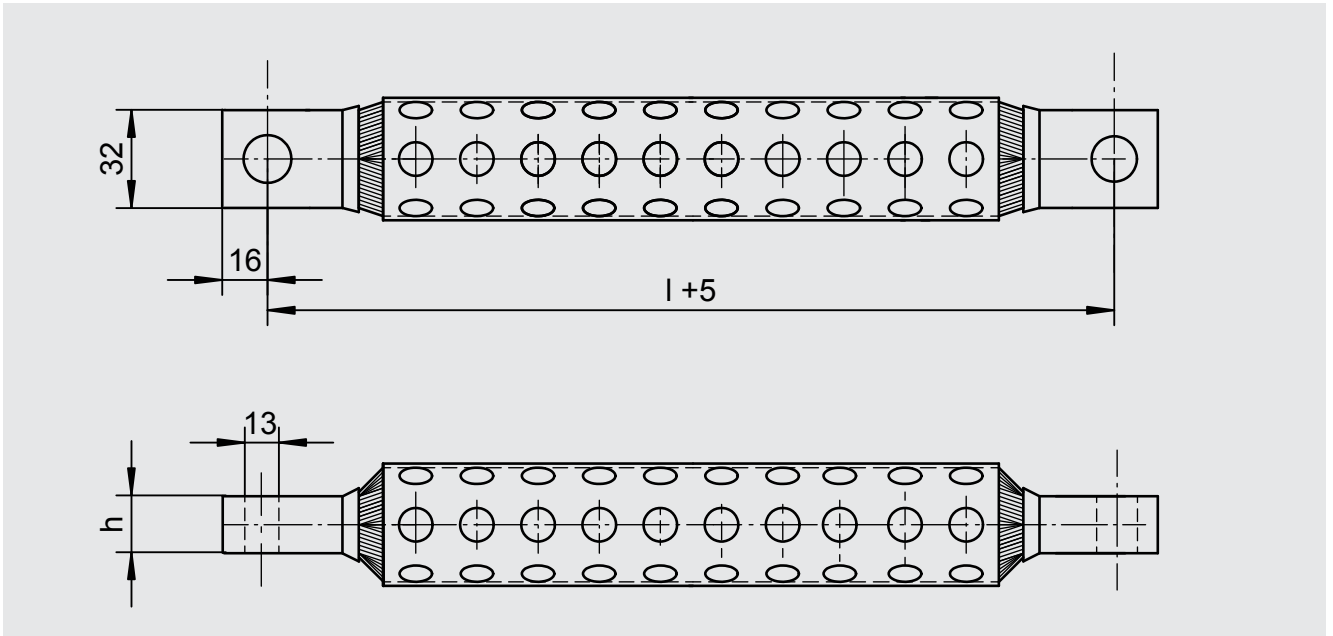

Connecting cables are available with perforated and unperforated pipe

Shape	Cross-section	h
D	300 mm <sup>2</sup>	15
F	400 mm <sup>2</sup>	20
G	500 mm <sup>2</sup>	24
H	600 mm <sup>2</sup>	26

Shape	L1
D	as required
F	as required
F	300
F	350
F	375
F	450
F	500
F	600
F	700
G	as required
G	300
G	500
G	550
G	600
H	as required
H	400

# Secondary connecting cable

two-core, water-cooled

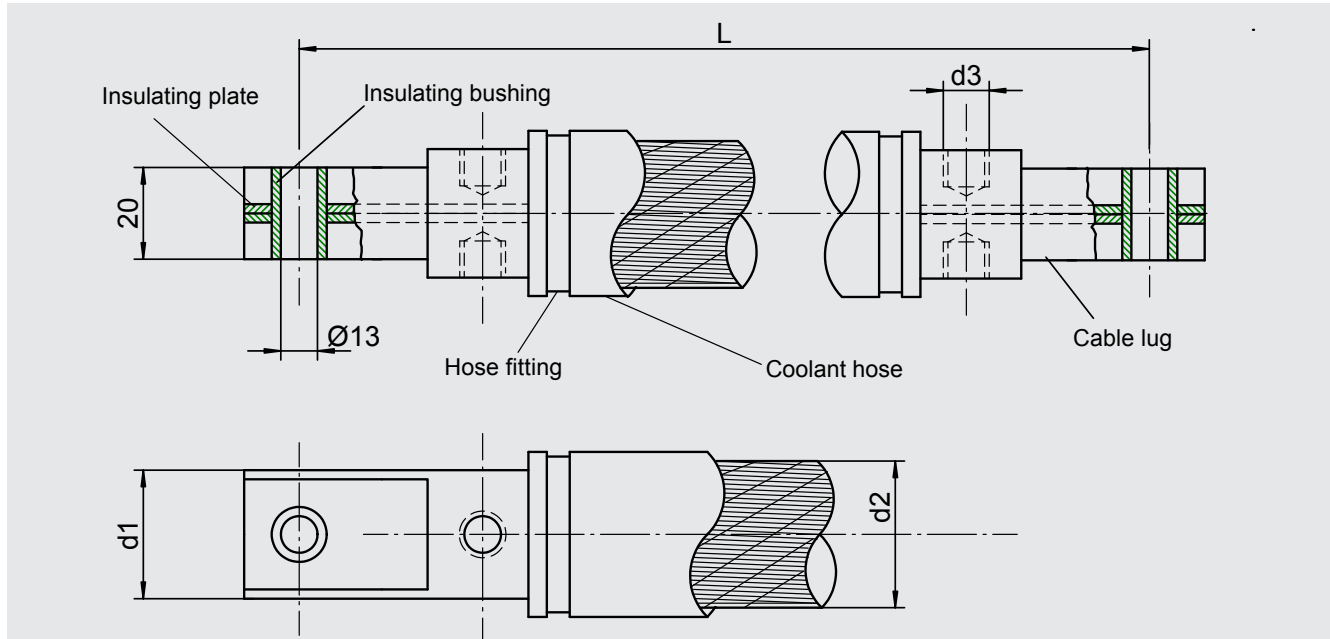

	Conductor cross-section				
	2 x 150	2 x 160	2 x 200	2 x 250	2 x 315
d1	34	35	38	41	50
d2	42	43	47	51	65
d3	G1/4	G1/4	G1/4	G1/4	G1/4
Length	Amissible continuous current				
1000	7500	8000	9000	10000	11200
1250	6700	7100	8000	9000	10000
1600	6000	6300	7100	8000	9000
2000	5300	5600	6300	7100	8000
2300	5000	5300	6000	6700	7500
2500	4750	5000	5600	6300	7100
3000	4500	4500	5000	5600	6300
3500	4000	4250	4750	5300	6000

Ordering example:

Two-core connecting cable, cross section 2 x 200 mm<sup>2</sup> length 2500 mm

= two-core connecting cable 2 x 200 - 2500

**Duro Metall GmbH**      **[www.duro-metall.com](http://www.duro-metall.com)**

Albert-Einstein-Str. 1, 70806 Kornwestheim, Germany, Phone +49 (0)7154 8255-0, Fax +49 (0)7154 8255-48, [info@duro-metall.de](mailto:info@duro-metall.de)

This brochure is for your general information only and is not subject to revision. No claims can be derived from it unless there is evidence of intent or gross negligence.  
The data presented is not guaranteed and does not replace expert advice.



0541-13 032/05.13 En 2 ODH (GSW/A)